

All parts in this quotation are belong to Intermediate shaft  
(K1452.03.05.00)

SL	Part No.	Description	Drawing Position SL. NO.
1	K1429.03.05.06Y2(TZ)	FRICTION WHELL CROWD GEARBOX SHOVEL WK-12C	23
2	K1451.03.05.07(TZ)	GEAR TOOTH QUANTITY: 116; OUTSIDE DIAMETER: 1420 MM; AIR BAG CROWD; ELECTRICAL ROPE SHOVEL TZ MODEL WK-12C	24
3	K1429.03.05.22(TZ)	GASKET AIRBAG CROWD; ELECTRICAL ROPE SHOVEL TZ MODEL WK-12C	59
4	K1452.03.05.32(TZ)	COUPLING, CROWD AIR BAG SYSTEM ; SHOVEL TZ WK-12C	77

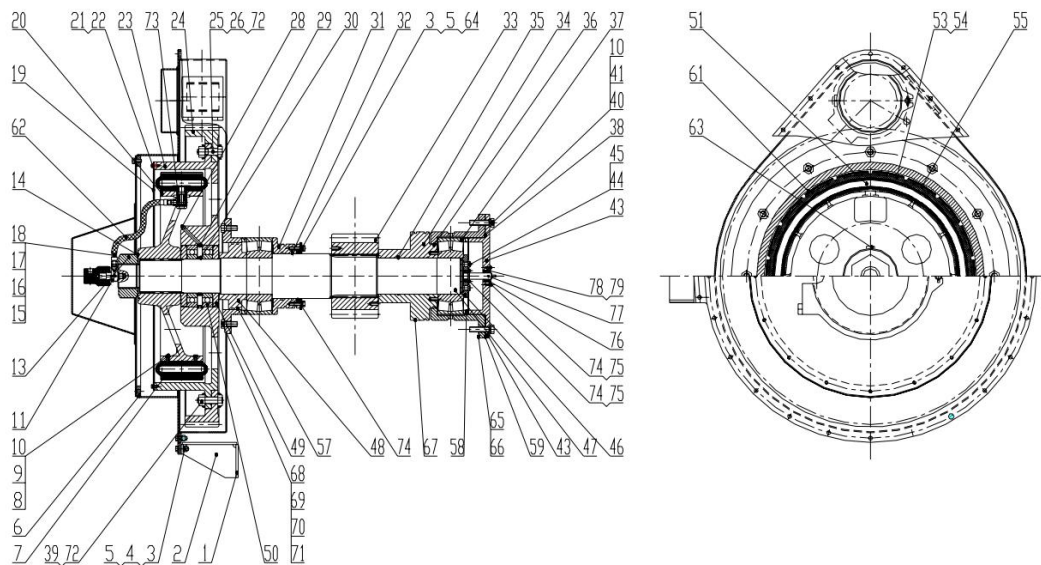

中间轴 Intermediate shaft (K1452.03.05.00)

The intermediate shaft assembly includes gear, pinion, intermediate shaft, support roller, attrition wheel, roller bearing, air bag, sluice shoes, air connector, gear cover, seals, and fasteners and so on.

Intermediate shaft, pinion and support wheel are all involution spline connection.

The pinion is a cylinder gear with involution tooth and made of forged carbon steel.

The attrition wheel is mounted on the intermediate shaft through a roller bearing. The attrition wheel is connected with the gear through fine bolts.

The gear is a cylinder involutes tooth and rim of the gear is carbonizing heat treated.

The module of the gear is 12 and the tooth number is 116.

The air bag is fitted in between the support wheel and the attrition wheel. The inside diameter of the air bag is connected with the support wheel through bolts. The outside diameter of the air bag is mounted with brake shoe. When the air bag is inflated, the friction disc on the shoe will tightly contact with the attrition wheel to have the function of transferring movement.

The air bag for the intermediate shaft is to limit the maximum transmission torque. The friction disc on the air bag will have relative slide towards the attrition wheel to release the energy and in this way realizing the torque limitation and protection of the equipment.

The air bag is to realize torque transmission and limitation through input of rated pressure from air compressed air. By the adjusting of the input air pressure, the maximum torque of the air bag can be changed.

In addition, the transformation of the air bag can automatically compensate the dimension deviation from the attrition of the disc.